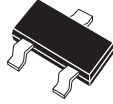

CMPTA44**NPN SILICON EXTREMELY
HIGH VOLTAGE TRANSISTOR****SOT-23 CASE**

Central™

Semiconductor Corp.

DESCRIPTION:

The CENTRAL SEMICONDUCTOR CMPTA44 type is a surface mount epoxy molded silicon planar epitaxial transistor designed for extremely high voltage applications.

MARKING CODE: C3Z

MAXIMUM RATINGS: ($T_A=25^\circ\text{C}$)

	SYMBOL		UNITS
Collector-Base Voltage	V_{CB0}	450	V
Collector-Emitter Voltage	V_{CEO}	400	V
Emitter-Base Voltage	V_{EBO}	6.0	V
Continuous Collector Current	I_C	300	mA
Power Dissipation	P_D	350	mW
Operating and Storage			
Junction Temperature	T_J, T_{stg}	-65 to +150	$^\circ\text{C}$
Thermal Resistance	θ_{JA}	357	$^\circ\text{C/W}$

ELECTRICAL CHARACTERISTICS: ($T_A=25^\circ\text{C}$ unless otherwise noted)

SYMBOL	TEST CONDITIONS	MIN	MAX	UNITS
I_{CBO}	$V_{CB}=400\text{V}$		100	nA
I_{CES}	$V_{CE}=400\text{V}$		500	nA
I_{EBO}	$V_{BE}=4.0\text{V}$		100	nA
BV_{CBO}	$I_C=100\mu\text{A}$	450		V
BV_{CES}	$I_C=100\mu\text{A}$	450		V
BV_{CEO}	$I_C=1.0\text{mA}$	400		V
BV_{EBO}	$I_E=10\mu\text{A}$	6.0		V
$V_{CE(SAT)}$	$I_C=1.0\text{mA}, I_B=0.1\text{mA}$		0.40	V
$V_{CE(SAT)}$	$I_C=10\text{mA}, I_B=1.0\text{mA}$		0.50	V
$V_{CE(SAT)}$	$I_C=50\text{mA}, I_B=5.0\text{mA}$		0.75	V
$V_{BE(SAT)}$	$I_C=10\text{mA}, I_B=1.0\text{mA}$		0.75	V
h_{FE}	$V_{CE}=10\text{V}, I_C=1.0\text{mA}$	40		
h_{FE}	$V_{CE}=10\text{V}, I_C=10\text{mA}$	50	200	
h_{FE}	$V_{CE}=10\text{V}, I_C=50\text{mA}$	45		
h_{FE}	$V_{CE}=10\text{V}, I_C=100\text{mA}$	20		
f_T	$V_{CE}=10\text{V}, I_C=10\text{mA}, f=10\text{MHz}$	20		MHz
C_{ob}	$V_{CB}=20\text{V}, I_E=0, f=1.0\text{MHz}$		7.0	pF
C_{ib}	$V_{EB}=0.5\text{V}, I_C=0, f=1.0\text{MHz}$		130	pF

R4 (26-September 2002)

SOT-23 CASE - MECHANICAL OUTLINE

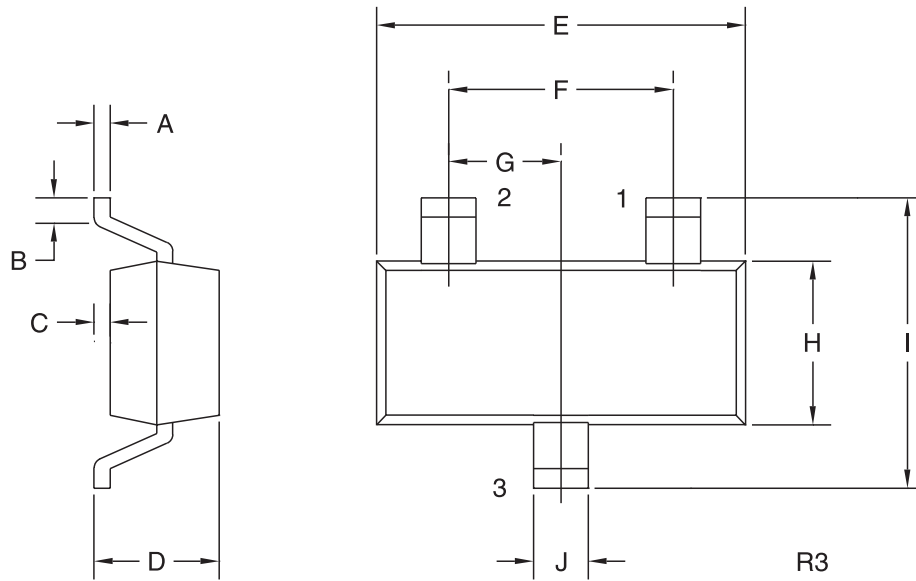

LEAD CODE:

- 1) BASE
- 2) EMITTER
- 3) COLLECTOR

MARKING CODE: C3Z

SYMBOL	DIMENSIONS			
	INCHES		MILLIMETERS	
	MIN	MAX	MIN	MAX
A	0.003	0.007	0.08	0.18
B	0.006	-	0.15	-
C	-	0.005	-	0.13
D	0.035	0.043	0.89	1.09
E	0.110	0.120	2.80	3.05
F	0.075		1.90	
G	0.037		0.95	
H	0.047	0.055	1.19	1.40
I	0.083	0.098	2.10	2.49
J	0.014	0.020	0.35	0.50

SOT-23 (REV: R3)